

CBYC Youth Winter Series

2022 - 2023

Sailing Instructions

<ul style="list-style-type: none">• Halloween Regatta 29th October 2022• Christmas Regatta 17th December 2022• Valentines Regatta 11th February 2023• Easter Regatta 25th March 2023	<ul style="list-style-type: none">• Compete in 3 out of 4 to qualify for the series• £25 Entry per Event• £75 Entry Fee for the series• 3 to 6 races a day• Prize giving at each event• Overall Series prizes at Easter Regatta
---	--

Objective

Racing events designed to build on the success of our summer program. Whilst quality racing is the intention of the series, courses may be adapted and training may be provided to suit the age and ability of competitors. The series will cater for experienced racers (wanting to practise against their squad mates!) through to novice sailors travelling to their first event and open to members and non members

The following fleets will be catered for;

Topper Gold	Racing for GBR, Welsh National Squad Sailors or those Top Regional Squad Sailors aspiring to gain a place in next year's Welsh National Squad.
Topper Silver	Racing for the Regional Squad Sailors or those aspiring to gain a place in next year's Regional Squad.
Topper Training	Racing & Training provided for less experienced sailors. Those taking part in their first few events or not yet ready for main fleet racing or who have come from the RYA OnBoard scheme with 6wks experience.
Optimist Gold	Racing for GBR, Welsh National Squad Sailors or those Top Regional Squad Sailors aspiring to gain a place in next year's Welsh National Squad.
Optimist Silver	Racing for the Regional Squad Sailors or those aspiring to gain a place in next year's Regional Squad.
Optimist Training	

Please Note

- o Gold and Silver fleets will be scored together to enable sailors to monitor their progress.
- o The training fleets may sail a different course to the Gold and Silver fleet

Sailing Instructions

1. RULES

1.1. The Event is governed by the rules as defined in the Racing Rules of Sailing.

1.2. Competitors should note that RYA Cymru Wales implement the RYA Racing Charter and that they will be required to undertake to sail in compliance with the Charter, which can be found at the front of the RYA rule book or at www.rya.org.uk/racing/charter

1.3. Post Race Penalty and the Advisory Hearing and RYA Arbitration of the RYA Rules Disputes Procedures will be available.

2. CONDITIONS OF ENTRY

2.1. Insurance

Each yacht shall be covered by third party insurance to a minimum value of £2,000,000.

2.2. Classes and eligibility

Racing will be in the Optimists and Toppers. Entries will be accepted in these classes from

- a) Optimist sailors under 16 on 31/12/2022
- b) Topper sailors under 19 on 31/12/2022

2.3. Tally Systems may be used.

2.3.1 The use of tally will be announced at the briefing. Tally procedure may either consist of Beach Master controlled launch, a Tally Board to be controlled by the Beach master or a Sign on Sign Off sheet. No boat may launch before Beach Master confirms launch go ahead and collecting their tally if in operation. Immediately on coming ashore, helms shall return their tallies to the tally board.

2.3.2 The **penalty** for not complying with this instruction will be a contribution to the RNLI, made before the end of Protest Time, of £2 for the first offence, £4 for the second and so on, provided for in rule 64.1 (a) (*penalties and exoneration*). Failure to comply with this instruction shall not be grounds for protest by another boat, changing rule 60.1 (*right to protest*).

3. NOTICES TO COMPETITORS

3.1. Notices to competitors will be posted on the Official Notice Board, which will be located in or around the club house and identified at the briefing.

4. CHANGES IN SAILING INSTRUCTIONS

4.1. Any change to the sailing instructions (SI) will be posted at least 30 minutes before the advertised starting time of the race or races concerned.

5. SIGNALS MADE ASHORE

5.1. Signals made ashore will be displayed on a staff identified at the briefing.

5.2. When flag AP is displayed ashore, '1 minute' is replaced with 'not less than 30 minutes' in the race signal AP.

6. SCHEDULE OF RACES

6.1. Dates of racing are as the series NOR describes. Not more than 4 events will be held. An event days racing may be rescheduled if one or more days racing are abandoned.

6.2. A Maximum of 6 races a day are scheduled.

6.3 Warning signals: **10:55** for the 1st race of the day, at all events.

6.4 To alert boats that a race or sequence of races will begin soon, an orange flag will be displayed on the committee boat not less than four minutes before a warning signal is displayed.

7. CLASS SIGNALS

7.1. Class flags will be:

Optimist	International Code Flag O
Topper	International Code Flag T or Topper Class Insignia*

* Check at briefing

7.2. If Optimist Training fleet starts are to be separate the additional flag will be described at the briefing

8. COURSE AREAS

8.1. The course areas to be used will be announced at the briefing.

9. THE COURSES

9.1. The course configuration and order of rounding marks is shown in Appendix A to these Sailing Instructions.

9.2. The Course will be identified by the display of the appropriate numeral pennant below the class flag during starting sequence.

9.3. If no numeral pennant is displayed, Optimists will sail course '2', Toppers 'course 1'.

[The Intended course length is approximately 20 – 30 minutes for the lead boat]

10. MARKS

10.1. Course marks to be used will be notified at briefing.

11. THE START

11.1. The starting line will be between a staff displaying an orange flag or shape on the race committee boat at the starboard end and the port end starting mark as shown in the course diagram.

11.2. Boats whose warning signal has not been made shall avoid the starting area.

11.4. In the event of General Recall the warning signal for the recalled class shall be made one minute after the First Substitute is removed (one sound), and the starts for any succeeding classes shall follow the new start.

12. CHANGE OF COURSE

12.1. To change the next leg of the course, the race committee will move the original mark to a new position.

12.2. If the race committee signals a shortened course (displays flag S with two sounds) the finishing line shall be: at a rounding mark, between the mark and a staff displaying flag S.

13. THE FINISH

13.1. The finishing line will be between a staff displaying a blue flag on a race committee boat and the finishing mark.

13.2. Boats may be finished at any point on the course by a race committee boat displaying Flag W or letter W accompanied by 1 sound signal.

14. TIME LIMITS

14.1. A Race time of 1 hour and Mark 1 time limit of 20 minutes shall apply to the lead boat in each class.

15. PROTESTS

- 15.1. Protests shall be written on forms available at the race office and delivered there within 40 minutes after the time of the last boat's finish in their class. If races are sailed back-to-back protests shall be lodged within 40 minutes of the finishing time of the last boat in their class in the last race of the day.
- 15.2. All boats intending to Protest, must report to the appropriate Committee Boat at the end of each race. Failure to do so will render the Protest invalid. This changes rule 61.
- 15.3. Protests will be heard in approximately the order of receipt as soon as possible.

16. SCORING SYSTEM

- 16.1. The event will be scored using Appendix A Low point scoring system.
- 16.2. Each boat's event score will be the total of her race scores with her worst score discarded if 3 or more races have been completed.
- 16.3. Two races shall constitute a series

17. PRIZES

- 17.1. Each event will have prizes for each Class, the overall circuit Prizes will count 3 event results with 3 discards.

18. OUTSIDE HELP

- 18.1. At the discretion of the race committee official support boats only may help competitors. This amends Rule 41. The application of this SI shall not give grounds for redress. The extent of help will be dependent on ability, examples may include shortening courses for these boats, providing alternative courses to suit the conditions, coaching etc. This changes Rule 62.

19. RISK STATEMENT

It must be recognized that sailing is by its nature an unpredictable sport and therefore inherently involves an element of risk. By taking part in the event, you agree and acknowledge that:

- 19.1 You are aware of the inherent element of risk involved in the sport and you accept responsibility exposing yourself to such inherent risk whilst taking part in the event;
 - 19.2 You will comply at all times with the instructions of the Race Officer/Beach master and other officials particularly with regard to handling of boats, wearing of buoyancy aids and the wearing of suitable clothing for the conditions;
 - 19.3 You accept responsibility for any injury, damage or loss to the extent caused by your own negligence;
 - 19.4 You will not participate in the event whilst your ability to skipper or crew a dinghy is impaired by alcohol, drugs or whilst otherwise unfit to participate ;
- The provision of patrol boat cover is limited to such assistance, as can be practically provided in the circumstances.

20. FURTHER INFORMATION

- 20.1. For further information please see below:

CBYC Sailing Team
Cardiff Bay Yacht Club
Ferry Road
Cardiff
CF110JL
02920 666627
training@cbyc.co.uk

Appendix A

Course 1 (inner loop)

Start 1, 4, 1, 2, 3, finish

Default for Topper (Silver/Gold)

Option for General Handicap

All mark roundings to port

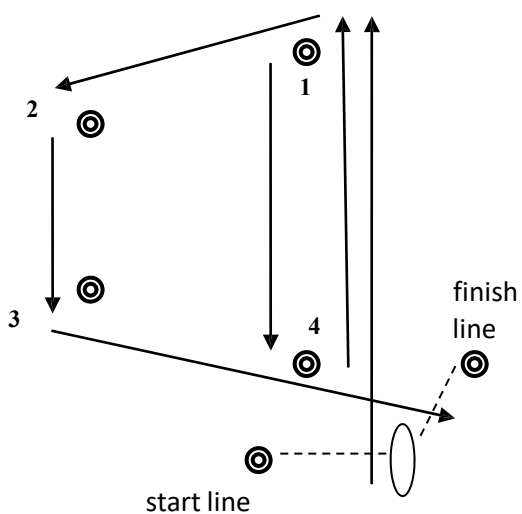

Course 2 (outer loop)

Start 1, 2, 3, 2, 3, finish

Default for Optimist (Silver/Gold)

All mark roundings to port

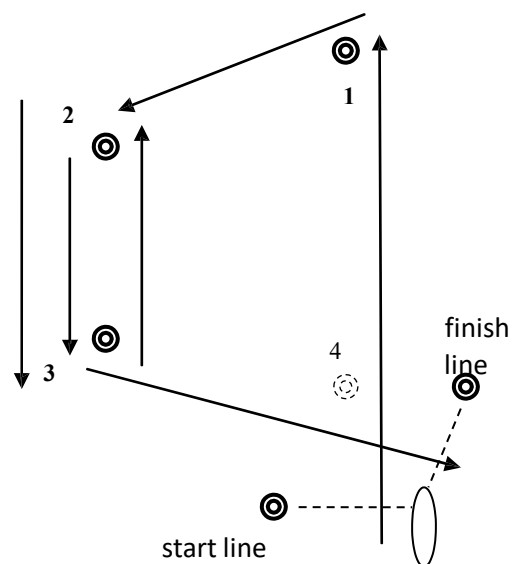

Course 3 (no loop)

Start 1, 2, 3, finish

Default for Optimist/Topper Training

All mark roundings to port

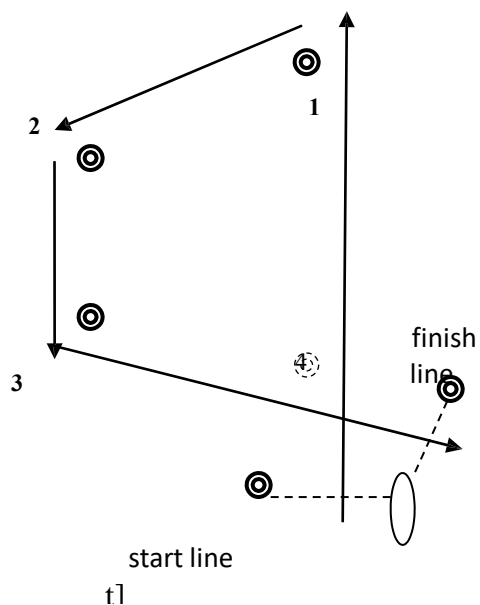

Course 4 (both loops)

Start 1, 4, 1, 2, 3, 2, 3, finish

Option for General Handicap

All mark roundings to port

